

REV.  
C

AS3505™

SAE Technical Standards Board Rules provide that: "This report is published by SAE to advance the state of technical and engineering sciences. The use of this report is entirely voluntary, and its applicability and suitability for any particular use, including any patent infringement arising therefrom, is the sole responsibility of the user." SAE reviews each technical report at least every five years at which time it may be revised, reaffirmed, stabilized, or cancelled. SAE invites your written comments and suggestions.

RATIONALE

GENERAL EDITORIAL REVISION, FIGURE 1 RE-DRAWN, TABLE 1 RE-FORMATTED, ADD ANSI Y14.5M (ASME PUBLICATION), CLARIFY THREAD B DESIGNATION, ADD NEW NOTE FOR DISPOSITION OF EXISTING INVENTORY, UPDATE MARKING NOTE.

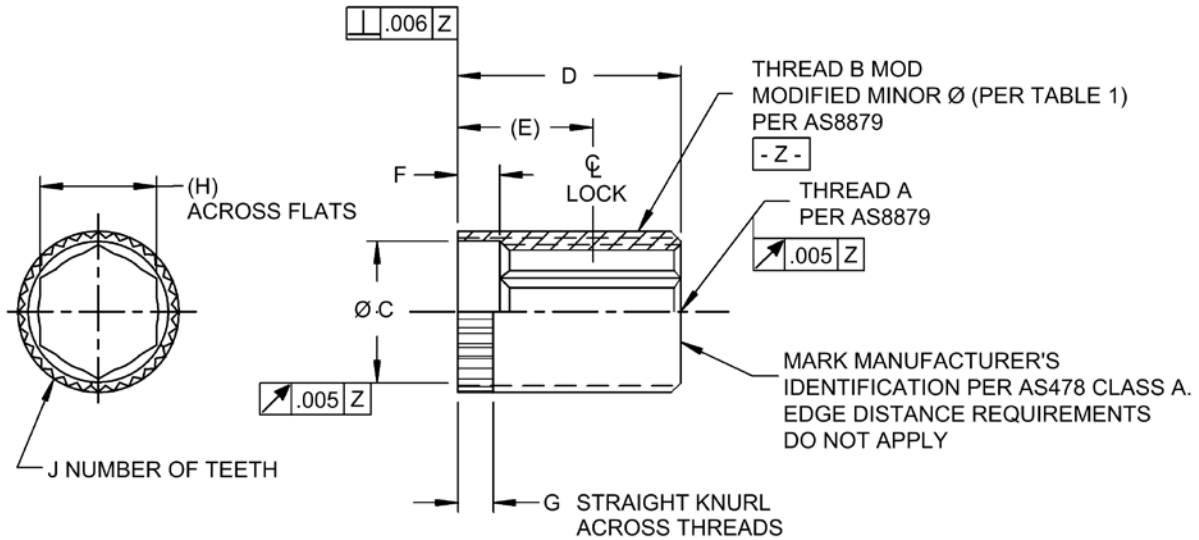

FIGURE 1 - INSERT

TABLE 1 - PART NUMBERS, THREAD A, THREAD B & MODIFIED MINOR Ø, AND DIMENSIONS ØC AND D

PART NUMBER	THREAD A	THREAD B MODIFIED MINOR Ø	THREAD B MINOR Ø MAX	ØC	D
AS3505-01	.1900-32 UNJF-3B	.2500-28 UNJF-3A	.2170	.193-.199	.465-.485
AS3505-02	.2500-28 UNJF-3B	.3125-24 UNJF-3A	.2785	.253-.259	.585-.605
AS3505-03	.3125-24 UNJF-3B	.3750-24 UNJF-3A	.3405	.315-.321	.710-.730
AS3505-04	.3750-24 UNJF-3B	.4375-20 UNJF-3A	.4010	.379-.385	.865-.885
/a/ AS3505-05	.4375-20 UNJF-3B	.5000-20 UNJF-3A	.4630	.441-.447	.990-1.010
/a/ AS3505-06	.5000-20 UNJF-3B	.5625-24 UNJEF-3A	.5290	.504-.510	1.115-1.135

/a/ AS3505-05 AND AS3505-06 ARE NOT TO BE USED FOR NEW DESIGNS.

SAE values your input. To provide feedback on this Technical Report, please visit <http://standards.sae.org/AS3505C>

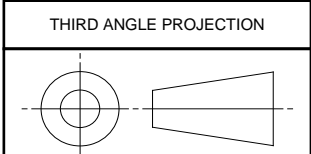

CUSTODIAN: E-25

PROCUREMENT SPECIFICATION: AS3506



AEROSPACE STANDARD

INSERT - THIN WALL, LONG, SELF-LOCKING, 1025 °F, SILVER PLATED ON INTERNAL SURFACES ONLY, UNS N07718, UNJ THREAD

AS3505™  
SHEET 1 OF 2

REV.  
C